



CS50 Continuous Siphon Overflow

CPR's Continuous Siphon Overflows provide the most efficient means of getting water to an external filter without expensive modifications to the tank. These precision-engineered overflows skim water from the surface of your aquarium at flow rates up to six times greater than units with tubes. Advantages such as water level adjustment, quiet operation, fish screen, and a black top to reduce algae growth all make the CPR Continuous Siphon Overflow the best on the market. Please read through the set up directions before and during the actual set up to ensure it is done correctly.

To place your overflow into operation:

1. *Open the packaging carefully and inspect the unit for damaged or missing parts. You should have:*
 - (1) *Overflow body*
 - (1) *Fish screen*
 - (1) *Pre-filter screen and sponge*
 - (1) *Vent tube with small "O" ring*
 - (1) *Bulkhead assembly*
 - (3) *Adjustment screws*
 - (1) *Air line*
 - (1) *Aqua Lifter pump and Acrylic Lid (included in Deluxe models)*

If any items are damaged or missing, please contact your dealer immediately.

2. *Before using the overflow for the first time it is important to decide where to position the unit. It is best to have the overflow as far away from the inflow as possible to reduce turbulence. It is also important to check the capacity of your sump as well as the flow rate of your return pump on your filtration system to prevent possible overflow. It will be necessary to add water to the system after it begins running. The amount of water that you will need to add will depend on the sump size and design.*
3. *Assemble the bulkhead fitting as shown in diagram A. Insert the pre-filter screen into the bulkhead and place the pre-filter sponge over the screen. Insert the vent tube into the hole at the top of the pre-filter screen. The "O" ring can slide up or down to adjust the height of the vent tube once the unit is operational.*
4. *Connect the bulkhead fitting to the hose going into your filtration system. You should use 3/4" Schedule 40 PVC inserted into the slip fitting inside the bulkhead. The PVC can be run directly into the filter or can be attached to 1" flexible line (using the optional PVC adapter available at Ameka Aquatics.com). **The fewest bends in the line will ensure the quietest operation.** To prevent leakage from where the PVC inserts into the bulkhead, you should use PVC cement to secure it into place. If using adapters other than PVC, All-Purpose Cement should be used to secure the plumbing in place.*
5. *Place the unit on the edge of your tank and allow the water to fill the front chamber. Adjust the lower adjustment screws so that the unit is parallel to the back of the tank.*

6. *Adjust the height of the unit with the two top adjustment screws so the water level is about ¼" above the edge of the front chamber.(FIG 1) Make sure that the overflow is level with the water surface, not necessarily the tank, as some tanks may not be perfectly level. If you have small fish, raise the fish screen so that the fish cannot enter the overflow. The screen should be raised above the water level to prevent fish loss. If you don't have small fish, discard the fish screen.*
7. *Using a container of water from your aquarium, fill the narrow chamber in the back of the overflow to the top.(FIG 2) To start and maintain the siphon overflow, draw the air out through the nipple on top of the overflow by one of the following methods:*
 - a) *With Aqua Lifter (highly recommended by CPR): Connect the nipple on top of the overflow to the inlet of the Aqua Lifter using airline tubing. Attach another piece of airline to the outlet of the Aqua Lifter. The outlet line may be placed in any of three places for drainage: the tank, the sump, or the overflow. Ensure that the end of the outlet line remains under water. This will prevent air from entering the system if power is lost or the pump malfunctions. See Diagram B. The Aqua Lifter not only constantly draws out air which can stop your siphon, but after a power outage they can restart the siphon when the power comes back on.*
 - b) *With a Venturi powerhead: A Rejuvenation Venturi powerhead (Rio 600RV) draws in air prior to the impeller and are very efficient. If placed inside the main tank, a check valve is needed to prevent back siphon through the airline during a power outage. This, however, reduces the ability of the powerhead to draw air out from the overflow, so a larger powerhead should be used. Another option is to place the powerhead in the sump.*
 - c) *Plugging the air nipple: Use the airline that came with your overflow. Attach one end to the air nipple on top of the overflow and a check valve on the other end to prevent air from being drawn in through the airline. You will need to initially draw out the air using a Venturi powerhead or your mouth and you will need to periodically draw out any air that accumulates.*
 - d) *Gravity siphon: Attach a long air line to the nipple on the overflow and, after drawing all the air out, place the end of the airline into a sump (which should be at least two feet below the overflow). This method is not as effective as those above.*
8. *When you initially start the siphon overflow, it will drain water from your aquarium down to the level of the front edge of the overflow box. The sump part of the filter should begin to fill with water. It may be necessary to add water to the sump if the return pump is not completely submerged. Make sure that the return hose is firmly attached to the return pump before plugging in the pump.*
9. *Plug in the return pump. The flow rate of the return pump should closely match up with the overflow rating of your CS Overflow model. Issues may arise if the return pump flow rate is significantly different than the recommended overflow rating. Keep an eye on the water level in the tank after the pump is plugged in to make sure the overflow starts its siphon. Water should start draining down the overflow.(FIG 3) Look into the side of the overflow box for any air pockets accumulating at the top. At this point, direct your attention to the sump to make sure the return pump is still completely submerged, or that the sump is not overflowing. It may be necessary to add or remove water from the sump at this point. Continue to monitor both the tank and the sump for a few minutes to ensure that the system is working consistently.*

10. The water level in the aquarium can be adjusted by using the two top adjustment screws on the overflow. This is usually necessary once the overflow has been operational for a few minutes. By lowering the water level in the aquarium you will raise the level in the sump and possibly overflow it. By raising the water level in the aquarium you will lower the water level in the sump and the return pump could possibly burn out if not completely submerged. Add or remove water as needed.
11. At certain flow rates, there will be a "flushing" noise coming from the overflow. This noise is caused by air trying to escape back up through the bulkhead while the water is going down. The enclosed vent tube will help reduce the level of noise. Place the tube through the small hole in the pre-filter screen and adjust it up or down until you find the point where the noise is reduced the most. Slide the small "O" ring down until it reaches the pre-filter screen, securing the position of the vent tube.

Your overflow is now in operation

The outside of your overflow may be cleaned with a non-abrasive cloth. Do not use detergent on any surface that comes into contact with aquarium water.

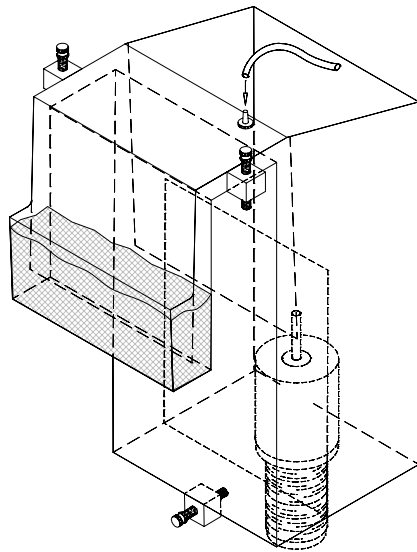

Fig.

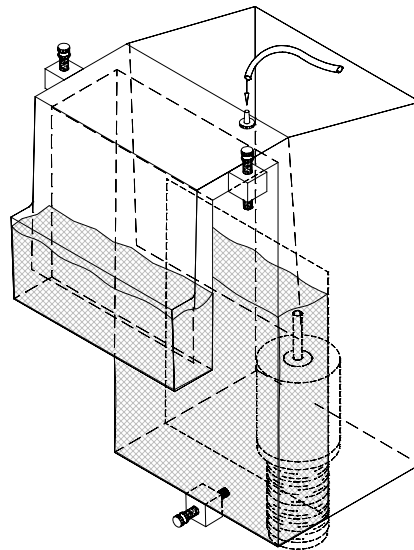

Fig. 2

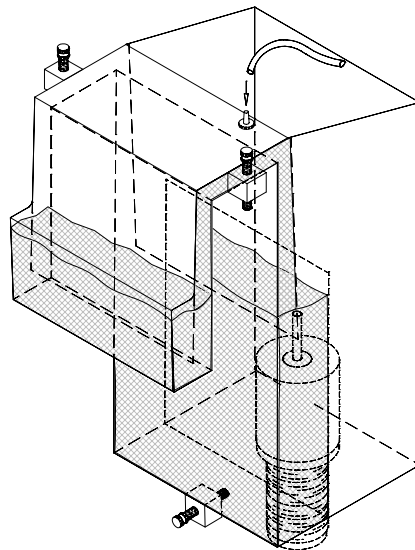

Fig. 3

***Aqua Lifter and lid included in Deluxe models**

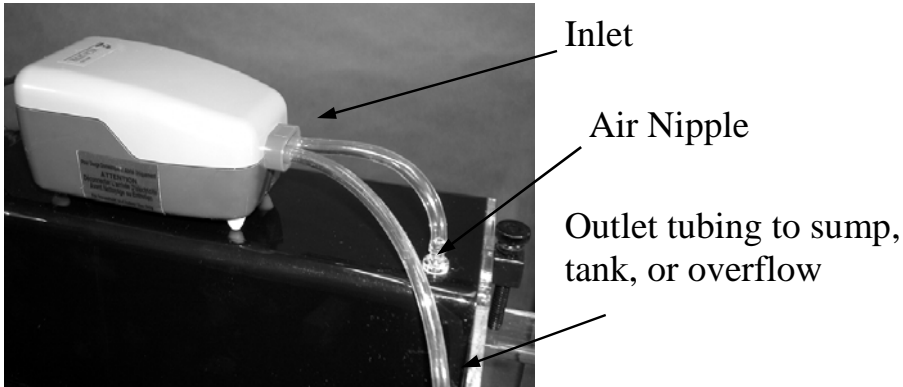

Diagram A

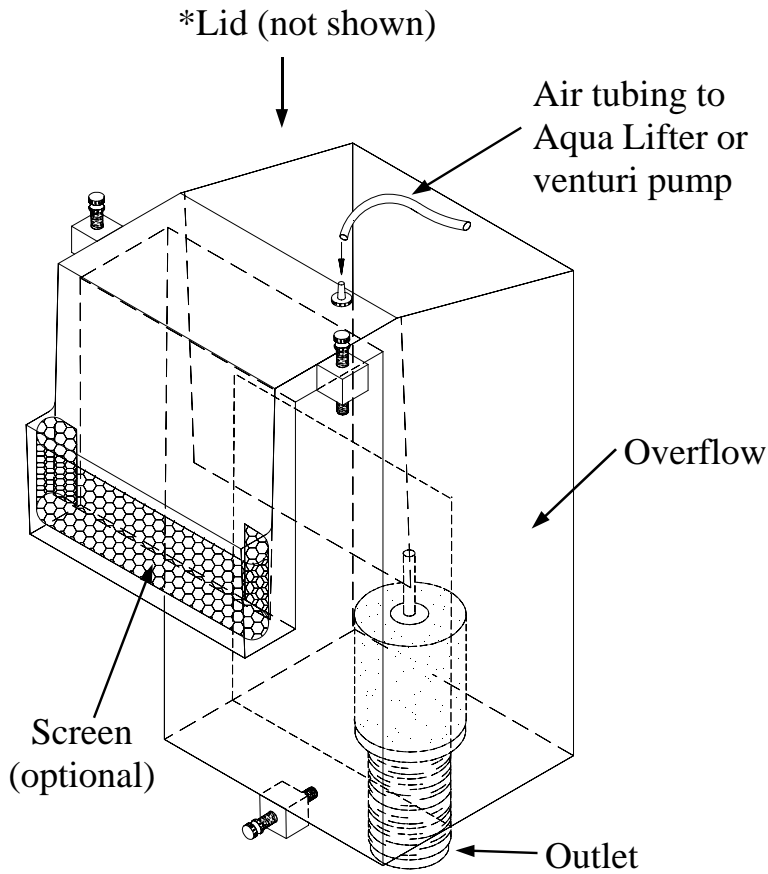
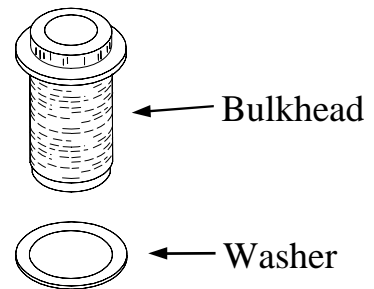
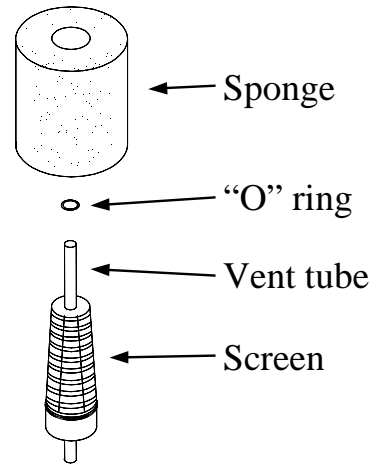

Diagram B

